



Specifications: RS82-EZ

Mounting hardware included

System Type	8.0" Coax, open-ceiling, ported (64 Watt transformer for 25/70.7/100 Volt or voice coil direct)
Impedance (nominal) ¹	16 ohm
Sensitivity dB @ 2.83 V/1 m	89.0 dB
Sensitivity dB @ 1 W/1 m ²	92.0 dB
Frequency Response (- 3 dB) ³	100 Hz - 22 kHz
Frequency Response (- 10 dB) ³	80 Hz - 22 kHz
Max. Program Power ⁴	128 W
Max. Continuous Power RMS ⁵	64 W
Max. Power SPL @ 1 m ⁶	110.0 dB
Tap Selector	6 Position rotary switch with transformer bypass
Transducer - Low Frequency Driver	203 mm (8.0 in.) Polypropylene cone, butyl rubber surround
Transducer - High Frequency Driver	25 mm (1.0 in.) silk dome tweeter with Beam Ring
Low Frequency Voice Coil	25.4 mm (1.00 in)
Crossover Frequency	2.5 kHz
Network Type: Low Pass	6dB per octave, 1st order
Network Type: High Pass	6dB per octave, 1st order
Enclosure Material	Injection molded ABS, glass fiber reinforced
Grille	Powder coated aluminum
Inputs	4 position ceramic terminal connector
Colors	Black or white (paintable)
Height	327.7 mm (12.9 in.)
Diameter	325.9 mm (12.8 in.)
Weight	5.0 kg (11.0 lbs.)
Shipping Weight	5.9 kg (13.0 lbs.)
Packaging	One per box
Included Accessories	Hanging hardware, weather plug, cover plate
Optional Accessories	N/A
Regulatory - UL	UL 1480 UEAY planned, UL 2239 approved
Regulatory - CE	Approved
RoHS	Approved

Transformer Taps

	70.7 V	Output	100 V	Output	25 V	Output
1	64 W	110.0 dB	64 W	110.0 dB	8 W	101.0 dB
2	32 W	107.0 dB	32 W	107.0 dB	4 W	98.0 dB
3	16 W	104.0 dB	16 W	104.0 dB	2 W	95.0 dB
	8 W	101.0 dB	8 W	101.0 dB	1 W	92.0 dB
	4 W	98.0 dB				

1 Impedance listed per IEC 60268-5

2 1 W 1 m sensitivity determined using nominal impedance

3 Frequency response measured in half or full space as dictated by speaker mounting configuration

4 Max program power is 3 dB above max continuous power

5 Continuous power rating, EIA-426-B test

6 Max output based on max continuous power

Key Features

- One 203 mm (8.0 in.) coaxial driver with BroadBeam Ring™ technology for consistently smooth high frequency directivity.
- Weatherized components for indoor and outdoor applications.
- Includes hanging hardware with galvanized steel cables and hanging bracket for fast, easy and secure installation. Unit may be hung or mounted direct-to-conduit via locking cover plate.
- Enclosure constructed of injection molded ABS with glass fiber reinforcement for lasting durability in indoor or outdoor applications.
- 16 ohm impedance for easy daisy chaining in low voltage systems.
- Aluminum grille with protective powder coated finish.
- Built-in thermal fuse.
- Unit ships in eco-friendly, recyclable packaging.
- UL 1480 UEAY planned, UL 2239 approved.
- High-quality black or white paint finish. Speaker is paintable.
- Included accessories: hanging hardware, terminal weather boot, cover plate.

Description

The RS82-EZ is an 8-inch, coaxial speaker designed for open-ceiling applications. Hanging hardware is included and features built in hanging bracket and screw on cover plate for fast, easy and secure installation. The unit may be mounted direct-to-conduit via the locking cover plate (see installation instructions for additional information). The RS82-EZ speaker incorporates 4 position ceramic terminal block input connector and a 6 position tap switch with transformer bypass position.

Applications

Designed for superior off-axis performance and easy installation, the RS82-EZ offers attractive styling in an economical speakers for open-ceiling uses. The RS82-EZ includes hanging cables and a built in mounting plate for suspending the speaker and a threaded opening on top



of its cover plate for direct-to-conduit mounting. Cost-effective engineering with high-performance sound makes the RS82-EZ speaker ideal for music and paging applications in retail, grocery stores, restaurants, hotels, casinos, museums, trade shows and conference rooms. For applications where additional bass is required, SoundTube's RS1001i-II-T 10-inch subwoofer may be used.

Patented SoundTube Technologies

SoundTube Entertainment and MSE Audio Group constantly develop new technologies that enhance audio product performance. SoundTube Entertainment innovations are protected by multiple U.S. and international patents, which explicitly cover SoundTube dispersion, enclosure and dome technologies. MSE Audio Group actively defends its patents in order to protect SoundTube resellers and end users.

Technical Data and Specification Tools

Technical Data

SoundTube Entertainment strives to provide complete and effective technical information and data to dealers, engineers and designers. All data are available from SoundTube Entertainment or at www.soundtube.com.

Technical data and downloads include:

EASE™ data – 3-D polar plots.

EASE™ Address – 2-D modeling for distributed systems

Autodesk® Revit® software

Tech Sheets – Technical information and architectural specs for system engineers

SoundTubeSPEC™ – Proprietary speaker placement software

Data Acquisition and Verification

All data for SoundTube speakers are independently collected from and verified by NWAALabs (www.nwaalabs.com) using their proprietary MACH testing system. All data are collected and analyzed according to ASTM, ISO

and AES standards using EASRA, TEF and MLSSA. Full balloon data including both phase and magnitude are compiled into a variety of formats including EASE 4.x, GLL and CLF.

Architectural Specifications

The loudspeaker shall consist of one 203 mm (8.0 in.) low frequency driver and one 25 mm (1.0 in.) high frequency driver. The low frequency voice coil diameter shall be 25.4 mm (1.0 in.).

Performance specifications of a typical production unit shall be as follows: Useable frequency response shall extend from 80 Hz – 22 kHz (-10 dB). Measured sensitivity (2.83-volt input, 1 meter) shall be at least 89.0 dB. The speaker shall have a nominal impedance of 16 ohms. The speaker shall be available for 25-, 70.7- and 100-volt modes and shall include a six-position tap switch with a transformer bypass position. Rated power capacity shall be at least 64 watts continuous (RMS) and conform to EIA-426-B testing. Maximum continuous output at 1 meter shall be 110.0 dB.

The high frequency transducer shall have a silk dome tweeter with BroadBeam Ring™ technology. The high frequency transducer shall have a convex aluminum tweeter with waveguide.

Installation shall be by galvanized steel cable attached to the speaker chassis via fixed cable end that interlocks with integrated mounting bracket. The external wiring input connector shall be a four-position ceramic terminal block for low impedance or distributed systems and shall accept from 10 – 22-gauge wire. The system shall be for indoor and outdoor applications and shall have a weather-resistant plug protecting all wire connectors inside the cover plate.

The enclosure shall be constructed of injection-molded ABS. The grille shall be constructed of powder-coated aluminum for lasting performance in the elements. Overall cabinet dimensions shall be no more than 327.7 mm (12.9 in.) in height by 325.9 mm (12.8 in.) in diameter. The unit shall weigh no more than 5.0 kg (11.0 lbs.) and shall include hanging hardware and weather-resistant cover plate plug.

The system shall be the SoundTube RS82-EZ with hanging hardware for

both low- and high-impedance applications.

SoundTube Entertainment

6430 Business Park Loop Road
Park City, Utah 84098

Phone 435.647.9555

Fax 435.647.9666

Toll Free 800.647.TUBE

www.soundtube.com

All SoundTube products come with a 5-year limited warranty.

RS82-EZ

Open-Ceiling Speaker

Preliminary Technical Information for System Engineers



SOUNDTUBE
ENTERTAINMENT

Graphs and Plots

Frequency Response

Impedance/Phase

Vertical Beamwidth

Directivity Index (DI)

RS82-EZ

Open-Ceiling Speaker

Preliminary Technical Information for System Engineers



SOUNDTUBE
ENTERTAINMENT

Polar Plots

———— Horizontal
----- Vertical

125 Hz

250 Hz

500 Hz

1,000 Hz

2,000 Hz

4,000 Hz

8,000 Hz

10,000 Hz

Mechanical Drawings

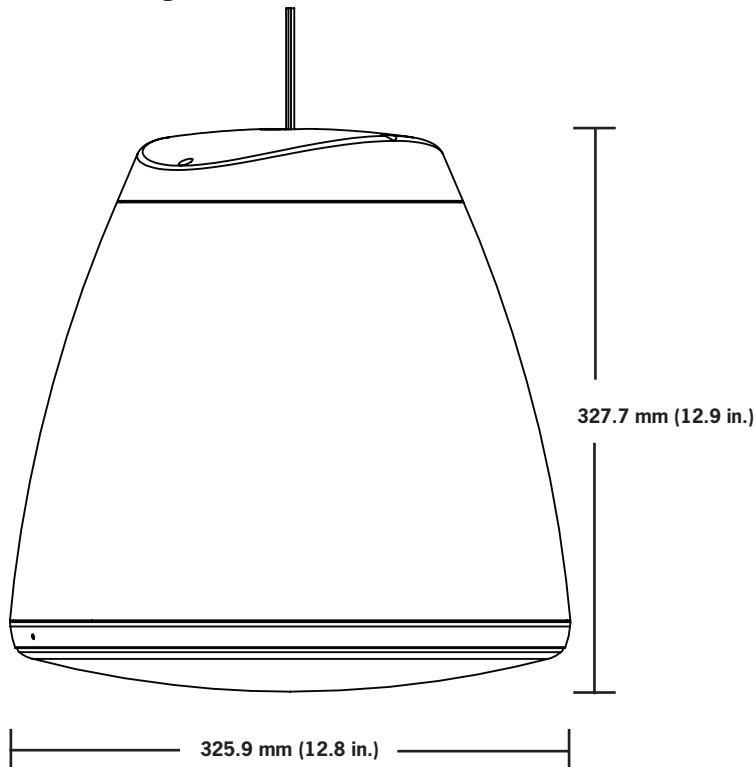

SoundTube Entertainment manufactures a complete line of speakers for:

Open-Ceiling • In-Ceiling • Surface-Mount • Outdoor • Sound-Focusing

All SoundTube products are designed and engineered in the USA.